

Butterfly Control Valve



DiskFlo

Control Valves

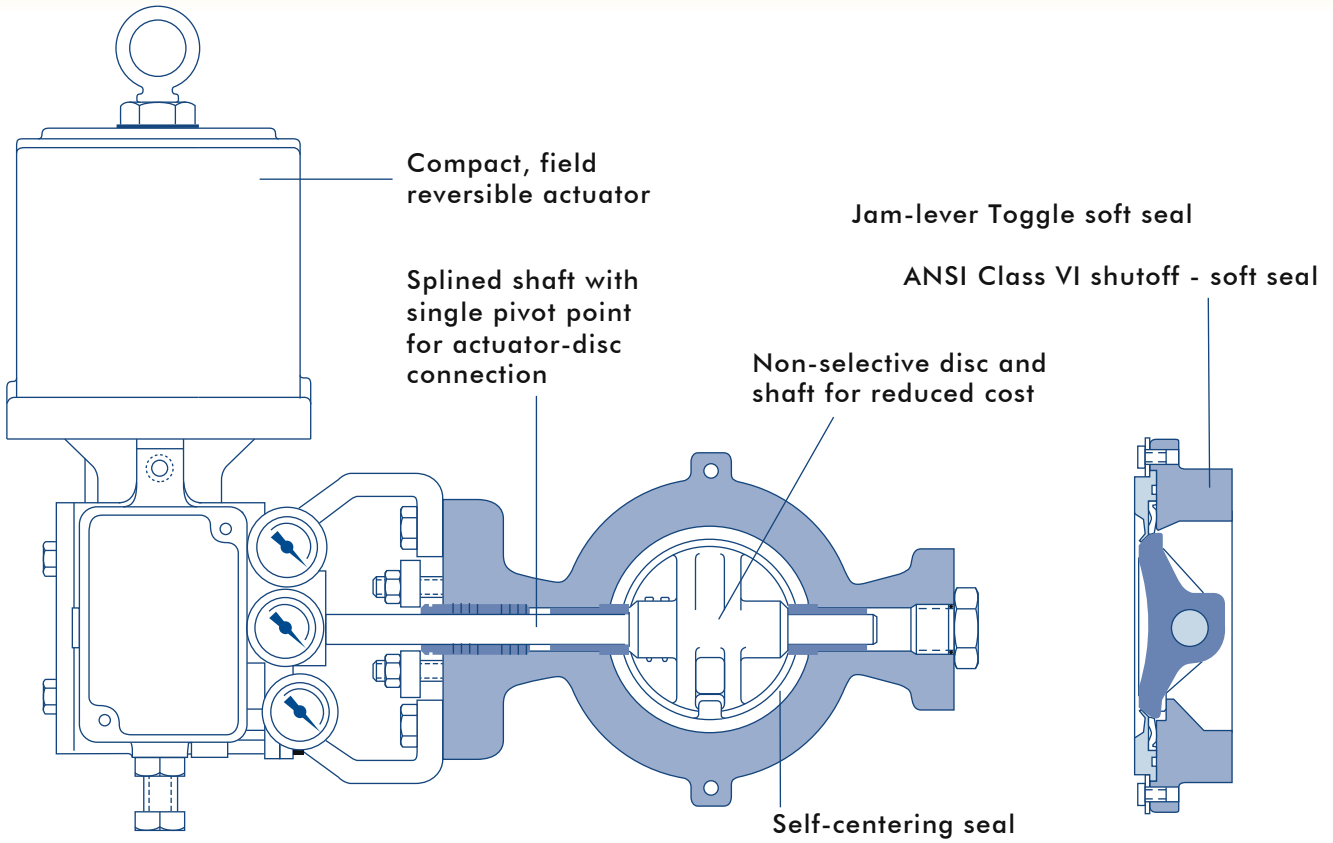

Figure 1: DiskFlo Design

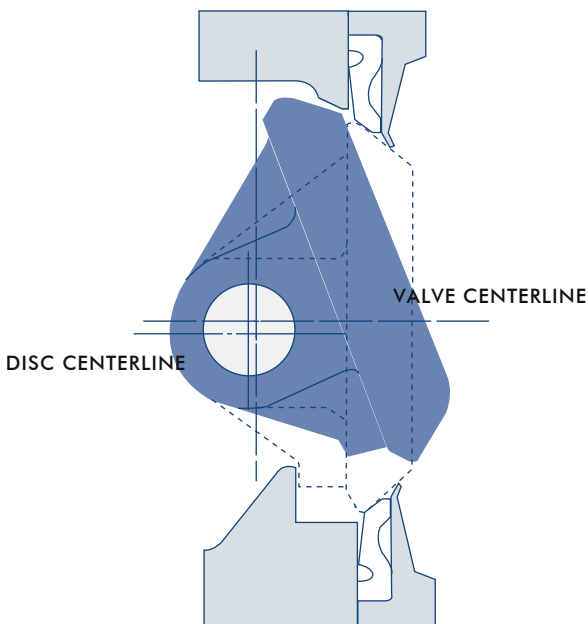

Figure 2: Eccentric-cammed Disc Rotation

Available in ANSI Classes 150 to 2500 and in sizes 2" to 72", this MASCOT rotary valve is available in alloys, carbon steel and 316 stainless steel. The high-performance DiskFlo rotary control valve is used to achieve bi-directional bubble-tight shutoff while maintaining low breakout torque at high and low pressure drops. The high-performance DiskFlo rotary control valve uses pressure assisted Jam-lever toggle seating concepts. By utilizing the pressure drop across the valve to aid the seating process, Jam-lever toggle seating assures low breakout torque.

The need for strong actuator seating force is reduced since much of the force is supplied by the pressure drop. To achieve especially high-performance throttling, even in large pressure drops close to the seat, it is combined with DiskFlo high thrust cylinder actuator and eccentric cammed disc.

DiskFlo Eccentric cammed disc:

To lift it out of the seat immediately upon actuation, a double offset has been designed into the disc. This avoids wear on the seat and disc, reducing leakage and parts replacement. The throttling also improves as the friction is eliminated.

DiskFlo



Features and Advantages

DiskFlo high performance is assured by the following features:

Features	Advantages
Jam-lever Toggle soft seat	<ul style="list-style-type: none"> • Bubble-tight shutoff equal to ANSI Class VI • Low breakout torque assures accurate throttling, even close to the seat • Non clogging seat design • Easy removal
Metal Seat Eccentric-cammed disc	<ul style="list-style-type: none"> • Shutoff better than ANSI Class IV • Disc pulls out of seat immediately, preventing seat wear • Accurate throttling due to disc profile when rotating into the seat
Single pivot-point, splined shaft	<ul style="list-style-type: none"> • Lost motion minimized between shaft and actuator
Bolted seat retainer	<ul style="list-style-type: none"> • Uninterrupted gasket surface allows for a wide variety of gasketing
Non-selective disc & shaft	<ul style="list-style-type: none"> • Easier maintenance • Reduced cost –replace part needed, not entire assembly
Wafer body	<ul style="list-style-type: none"> • Rugged and lightweight for easy handling and maintenance • One body serves ANSI Classes 150, 300 and 600 in sizes 2,3,4,6 & 8 • Industry standard MSS SP-67 permits shorter flange bolting than ball or cammed valves, increasing safety and reducing possibility of leakage
Flow capacity	<ul style="list-style-type: none"> • Capacity greater than globe, plug and cammed control valves
Concave disc	<ul style="list-style-type: none"> • Increased flow capacity
Disc stop in body	<ul style="list-style-type: none"> • Prevents damage to seat due to overstroking • Permits in-line disc relocation during maintenance
Wide variety of packing box configurations	<ul style="list-style-type: none"> • Purged bonnet and lubricator options
Fully enclosed, air purged transfer case	<ul style="list-style-type: none"> • Extra safety • Prevents atmospheric corrosion of actuator internals • Disc position indicator mounted on transfer case

DiskFlo also capitalizes on established features of MASCOT product lines:

Cylinder actuator	<ul style="list-style-type: none"> • High thrust for high-performance throttling • Compact and lightweight for easier servicing and maintenance • Fully interchangeable with VFlo ball valve actuator • Actuator air pressures allowable up to 150 psi
Wide interchangeability	<ul style="list-style-type: none"> • Spare parts stocking requirements minimized • Inventory costs reduced • Many GFlo and VFlo parts are interchangeable with DiskFlo
Available in variety of materials	<ul style="list-style-type: none"> • Carbon steel, 316 stainless steel and other alloys
Seat interchangeability	<ul style="list-style-type: none"> • Metal or Teflon ® seats easily installed
Spool-type four-way positioner	<ul style="list-style-type: none"> • Convertable between I/P and P/P • Calibration and maintenance easy due to fewer parts

The combined features designed into DiskFlo create a valve measurably superior to all other rotary valves. The information and specifications contained in the following pages are provided for comparison.

DiskFlo

Seating

To help energize the soft seat to bubble-tight shutoff in either flow direction, including alternating flow applications, Jam-Lever Toggle seating concepts utilize the pressure drop across the valve. Jam-lever Toggle soft seats achieve ANSI Class VI shutoff.

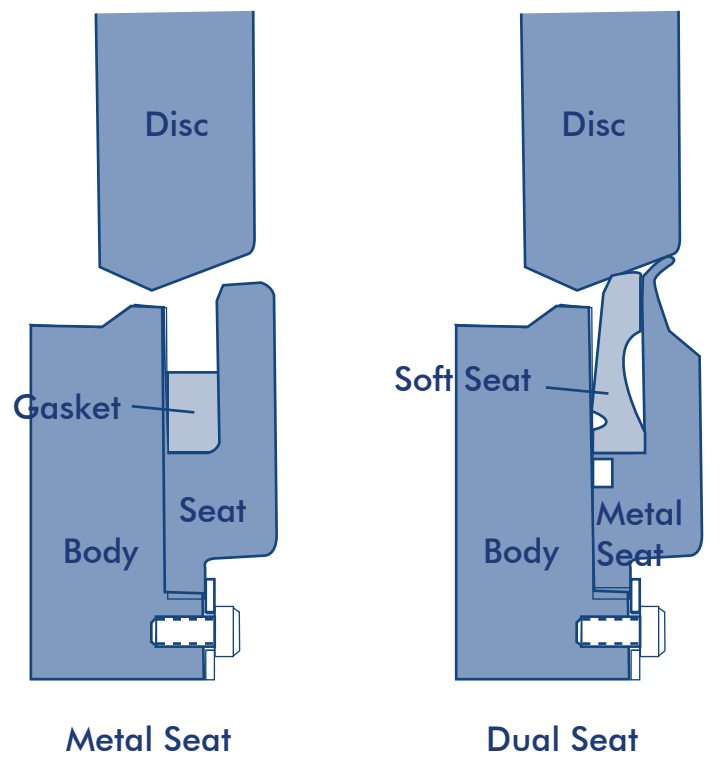
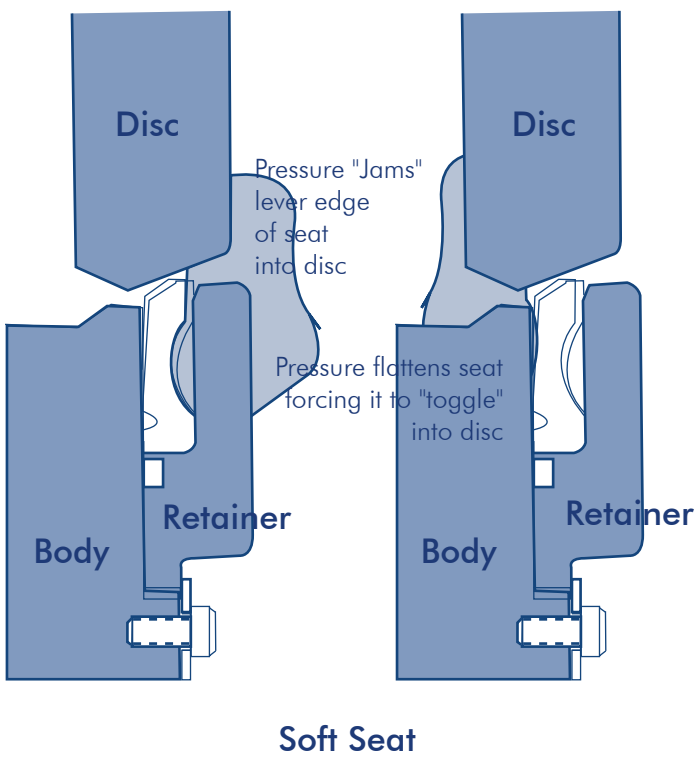
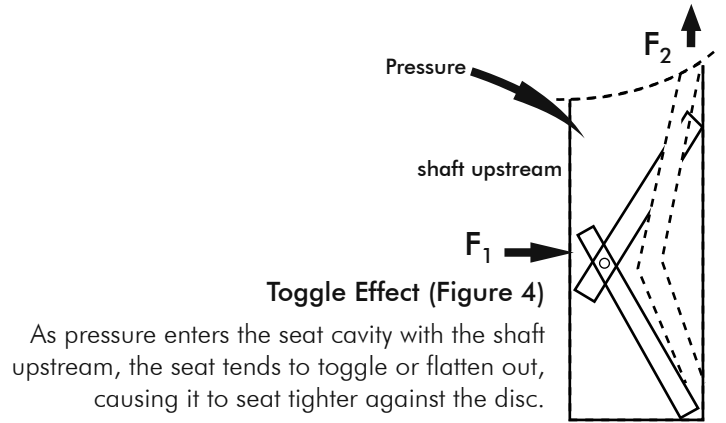
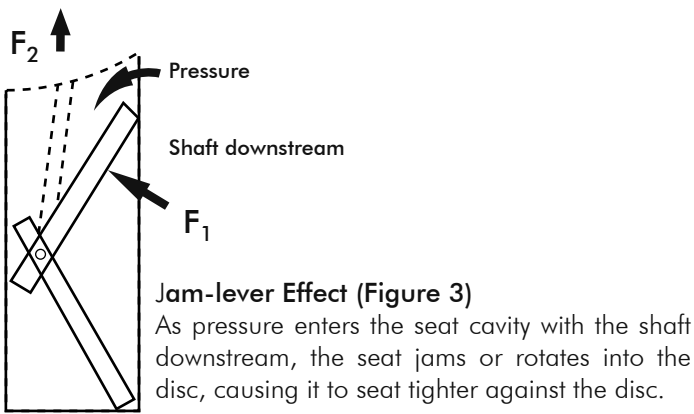

Figure 5 : Principles of Jam-lever Toggle Seating

Figure 6 : Additional Seat Configurations

DiskFlo



Seats & LPRF (F_L)

Metal Seat

For applications involving temperatures higher than those permitted by the Jam-lever Toggle soft seat, metal seats are used. A highly flexible lip, which assures full circle contact between the seat and disc when the valve is closed, is incorporated in the design. The lip flexibility permits breakout torque for the metal seat is the same or less than soft seat breakout torque. ANSI class IV shutoff is achieved through DiskFlo metal seats.

Dual Seat

DiskFlo dual seats incorporate both the Jam-lever Toggle soft seat and the flexible lip metal seat for added protection.

Flow Direction

Jam-lever Toggle seating allows DiskFlo to flow either shaft downstream or shaft upstream, depending on service conditions. With the shaft downstream the flow tends to open the valve. With the shaft upstream the flow tends to close the valve.

Flow Characteristics

The inherent flow characteristic of the DiskFlo valve is a modified parabolic. Other characteristics are obtained by substituting an interchangeable cam in the HiFlo positioner, to furnish the desired output. Cams are available to provide inherent linear and equal percentage flow characteristics as well as a linear relationship between signal and shaft rotation.

Liquid Pressure Recovery Factor (LPRF), F_L

The liquid pressure recovery factor, F_L , predicts the amount of pressure recovery that will occur between the vena contracta and the valve outlet. This accounts for the influence of the valve's internal geometry on the maximum capacity of the valve and the tendency to choke or cavitate. Smaller F_L will cavitate earlier. Figure 7 shows the F_L of the DiskFlo valve as compared to a typical butterfly valve. The DiskFlo F_L is between a typical butterfly and globe valve. The tendency to cavitate or choke will be more than a globe valve but less than the typical butterfly valve.

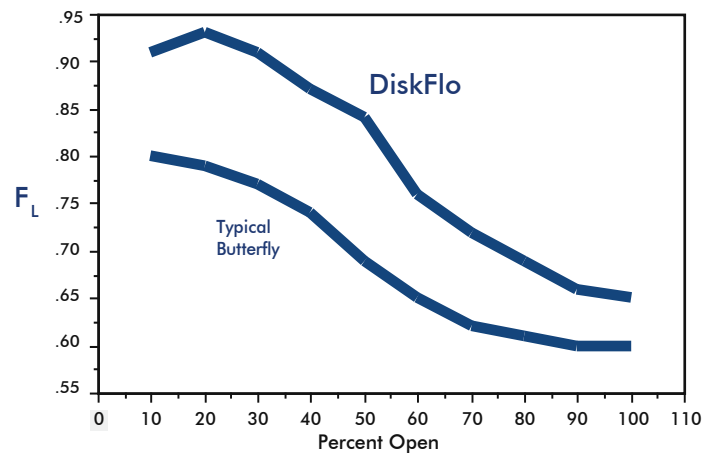

Figure 7: DiskFlo F_L Curves

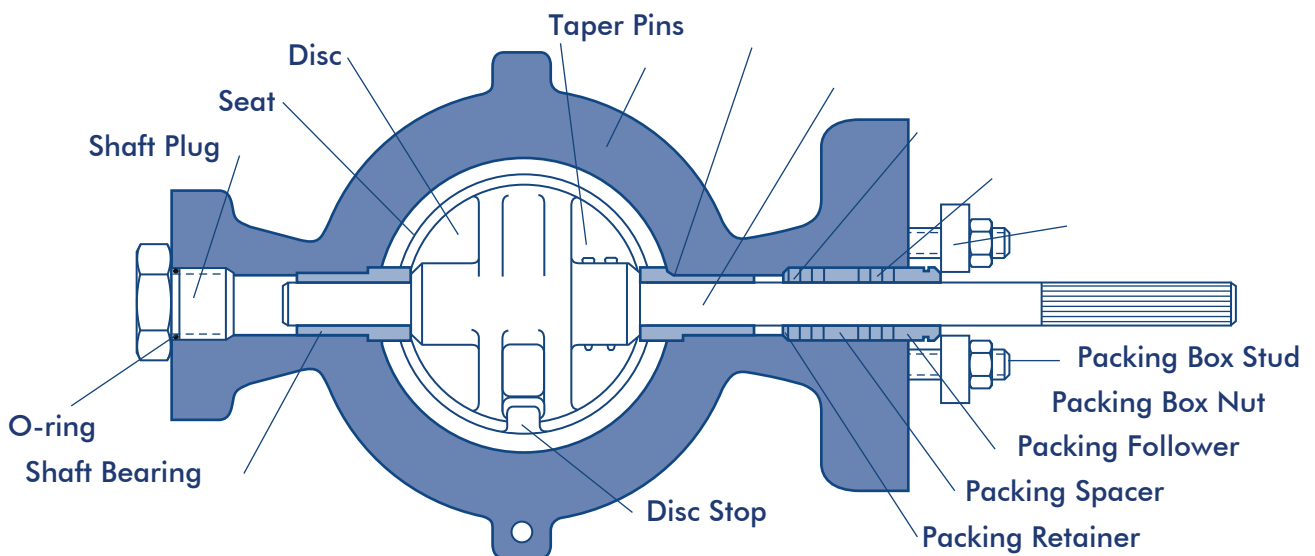

Figure 8: Body Subassembly, Section View

DiskFlo

Specifications

Table I: Maximum Allowable Shutoff Pressure Drops (psi)*

Valve Description	Flow Dir.	Temp. (°F)	Valve Size (inches)												
			2	3	4	6	8	10	12	14	16	18	20	24	30
Body: carbon steel Shaft & pins: 17-4 PH Disc: 316 stainless steel (1) or carbon steel Seat: TFE/Glass-filled (2)	Shaft Upstream or Downstream	-20 to 100	954	1000	1011	650	833	550	740	285	285	285	285	285	285
		200	705	705	705	650	705	550	705	260	260	260	260	260	260
		300	420	420	420	420	420	420	420	230	230	230	230	230	230
		400	150	150	150	150	150	150	150	150	150	150	150	150	150
		450	50	50	50	50	50	50	50	50	50	50	50	50	50
Body: 316 stainless steel Shaft & Pins: 17-4 PH or Nitronic 50 (3) Disc: 316 stainless steel Seat: TFE/Glass-filled (2)	Shaft Upstream or Downstream	-20 to 100	954	1000	1011	650	833	550	720	275	275	275	275	275	275
		200	705	705	705	650	705	550	705	240	240	240	240	240	240
		300	420	420	420	420	420	420	420	215	215	215	215	215	215
		400	150	150	150	150	150	150	150	150	150	150	150	150	150
		450	50	50	50	50	50	50	50	50	50	50	50	50	50
Body: 316 stainless steel or carbon steel** Shaft & Pins: Nitronic 50 (4) Disc: 316 stainless steel	Shaft Downstream	-450 to 200	593	593	593	593	593	593	593	275	275	275	275	275	275
		400	370	370	370	370	370	370	370	240	240	240	240	240	240
		600	318	318	318	318	318	318	318	215	215	215	215	215	215
		800	310	310	310	310	310	310	310	150	150	150	150	150	150
Body: 316 stainless steel or carbon steel** Shaft & Pins: Nitronic 50 (4) Disc: 316 stainless steel	Shaft Upstream	-450 to 200	296	296	296	296	296	296	296	275	275	275	275	275	275
		400	185	185	185	185	185	185	185	185	185	185	185	185	185
		600	159	159	159	159	159	159	159	159	159	159	159	159	159
		800	155	155	155	155	155	155	155	150	150	150	150	150	150
Body: 316 stainless steel Shaft & Pins: 17-4 PH Disc: 316 stainless steel Seat: PEEK	Shaft Upstream or Downstream	-20 to 100	954	1000	1011	650	833	550							
		200	720	720	720	650	720	550							
		300	530	530	530	530	530	530							
		400	300	300	300	300	300	300							
		500	70	70	70	70	70	70							
Body: Monel 400 Shaft & Pins: Monel K-500 Disc: Monel Seat: TFE/Glass-filled (2)	Shaft Upstream or Downstream	-20 to 100	865	910	920	592	758								
		200	705	705	705	592	705								
		300	420	420	420	420	420								
		400	150	150	150	150	150								
		450	50	50	50	50	50								
Body: Hastelloy C Shaft & Pins: Hastelloy C Disc: Hastelloy C Seat: TFE/Glass-filled (2)	Shaft Upstream or Downstream	-20 to 100	735	780	790	509	655								
		200	700	705	705	492	631								
		300	420	420	420	420	420								
		400	150	150	150	150	150								
		450	50	50	50	50	50								
Body: Alloy 20 (5) Shaft & Pins: Alloy 20 Disc: Alloy 20 Seat: TFE/Glass-filled (2)	Shaft Upstream or Downstream	-20 to 100	295	321	340	220	276								
		200	258	281	297	191	239								
		300	218	238	251	161	202								
		400	150	150	150	150	150								
		450	50	50	50	50	50								

* Consult factory for higher pressure drops and different material component combinations.

** Do not use WCB carbon steel below -20°F

(1) 316 stainless steel disc standard through 8-inch, carbon steel chrome plated disc standard 10 to 72 inch

(2) Maximum allowable shutoff delta pressure reduced 70 psi for virgin Teflon

(3) Hardened

(4) At temperatures above 800°F, Inconel 718 shaft and pins must be used.

(5) Alloy 20 has not been formally listed by ANSI or ASME for temperatures above 300°F.

Specifications

**Table II: Maximum Allowable Inlet Pressures*
for Various Body Ratings and Temperatures (psi)**

Temp. °F	WCB Steel (A216)**			316 Stainless Steel (SA-351-CF8M)**			Alloy 20 (A351-CN7M)**			Hastelloy C™-276**			Monel™ 400**		
	Pressure Class			Pressure Class			Pressure Class			Pressure Class			Pressure Class		
	150	300	600	150	300	600	150	300	600	150	300	600	150	300	600
-20 to 100	285	740	1480	275	720	1440	230	600	1200	290	750	1500	230	600	1200
200	260	675	1350	240	620	1240	215	555	1115	260	732	1465	200	530	1055
300	230	655	1315	215	560	1120	200	525	1045	230	693	1388	190	495	990
400	200	635	1270	195	515	1030				200	693	1388	185	480	955
500	170	600	1200	170	480	955				185	600	1200	170	475	950
600	140	550	1095	140	450	905				140	550	1095	140	475	950
700	110	535	1065	110	430	865				110	535	1065	110	475	950
800	80	410	825	80	415	830				80	410	825	80	460	915
900	50	170	345	50	395	790									
1000	20	50	105	20	365	725									
1100					325	645									
1200					205	410									

* For Maximum P, refer to Table I.

** Values as recorded in ANSI B16.34-1988.

Table III:

C_v - Flow Coefficients/Flange Compatibility

Body Size (inches)	C _v (90° rotation) normal flow	ANSI Rating Flange Compatibility (pressure class)*
2	54	150, 300, 600
3	190	
4	390	
6	975	
8	1700	
10	2700	150, 300
12	4000	
14	6600	150
16	8200	
18	10000	
20	13500	
24	20000	
30	31000	

* Consult factory for higher pressure classes

Table IV: Seat Leakage

Metal Seat	ANSI Class IV
Jam-lever Toggle Soft Seat	ANSI Class VI
Flow ring	2% of rated C _v
Dual Seat	ANSI Class IV

**Table V: Estimated Shipping Weights (lbs)
(with Actuator and Positioner)**

Valve Size	Weight	Valve Size	Weight
2	40	14	280
3	50	16	320
4	60	18	390
6	80	20	540
8	120	24	680
10	190	30	830
12	250		

DiskFlo

Specifications

Table VI: Material Selection Temperature Chart

		Temperature (°F)																											
		-450	-400	-350	-300	-250	-200	0	200	250	300	350	400	450	500	550	600	650	700	750	800	850	900	950	1000	1050	1100	1150	1200
Body / Disc	316 Stainless Steel	[Shaded]																											
	Carbon Steel	[Shaded]																											
	Monel	[Shaded]																											
	Hastelloy C	[Shaded]																											
	Alloy 20 ⁽¹⁾	[Shaded]																											
Shaft	17-4 PH	[Shaded]																											
	Nitronic 50	[Shaded]																											
	Inconel	[Shaded]																											
	Monel	[Shaded]																											
	Hastelloy C	[Shaded]																											
Bearings	Nitronic 60 / SFL ⁽³⁾	[Shaded]																											
	304 Stainless Steel / Teflon Lined	[Shaded]																											
	Filament Wound Glass / Teflon Lined	[Shaded]																											
	Stellite No. 6	[Shaded]																											
Soft Seat	Glass-filled TFE	[Shaded]																											
	Virgin Teflon	[Shaded]																											
	PEEK	[Shaded]																											
	Kel-F	[Shaded]																											
Metal Seat	316 Stainless Steel	[Shaded]																											
	316 Stainless Steel w/Stellite Overlay	[Shaded]																											
	17-4 PH	[Shaded]																											
	Inconel	[Shaded]																											
Packing	Teflon V-rings	[Shaded]																											
	Glass-filled Teflon V-rings	[Shaded]																											
	Grafoil	[Shaded]																											
	Braided Asbestos Free ⁽³⁾	[Shaded]																											

(1) Permissible at temperatures above 1000° F, but not recommended for prolonged exposure at these elevated temperatures because of the possibility of graphitization.

(2) Alloy 20 has not been formally listed by ANSI or ASME for temperatures above 300° F.

(3) SFL indicates Solid Film Lubricant, a coating containing MoS₂. Not for use in dry services.

(4) Garlock 127 AFP or equivalent

The darker shaded areas indicate increased temperature capacity of an extended body.

Mounting Orientations

The MASCOT spring cylinder rotary actuator also capitalizes on established feature of other MASCOT

Features	Advantages
Interchangeability	Minimizes requirements stocking spare parts Reduced inventory costs Uses indentational parts in differing rotary actuator sizes Utilizes many MASCOT Liner actuator parts
Spool-type four-way Positioner	Provides high-performances modulating positioner control Ensures ease of calibration and maintenance due to fewer parts
MASCOT's rotary spring cylinder actuator features high torques, positioning stiffness and easy maintenance to produce a high-performance rotary actuator	

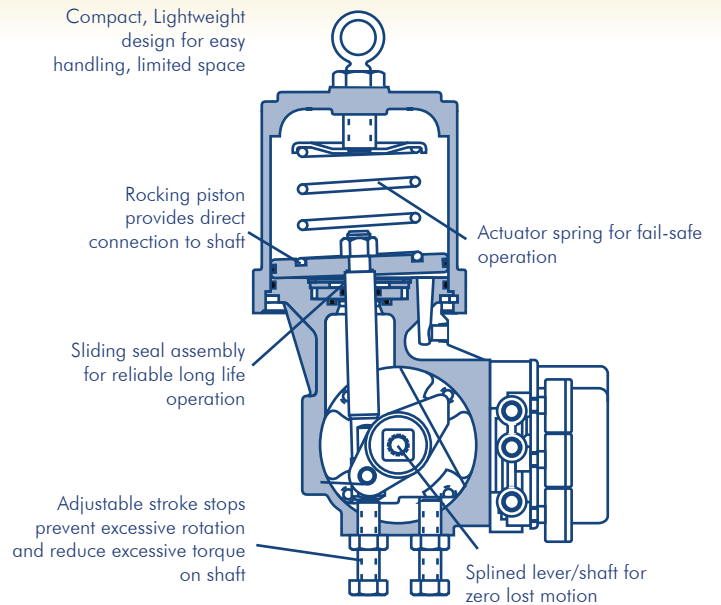

Figure 9

Spring Cylinder Rotary Actuator Features

Features	Advantages
Accepts	up to 150 psi air supply Achieves higher torques. Obtains stiff piston positioning. Permits higher P limits on valve.
Rocking piston	Provides direct connection to shaft. Assures zero lost motion between actuator and valve Utilizes fewer parts
Splined shaft and lever	Allows zero lost motion.
Compact, lightweight, rugged	Permits easy maintenance Installs in limited space applications. Easily meets seismic requirements.
Low friction bearing	Provide millions of cycles with minimal wear Combined with direct linkage, provides very low hysteresis.
Field reversible	Requires no extra parts Permits fast, easy field reversing Requires no change of spring action.
Fail-safe spring	Moves actuator to failure position without pressure assistance
Air-purged, fully enclosed transfer case	Prevents corrosion of linkage Ensures safe operation Contains external position indicator Allows four mounting positions without retubing, changing or adding parts
Stroke stops	Allow both ends of stroke to be adjusted

DiskFlo

Overall dimensions

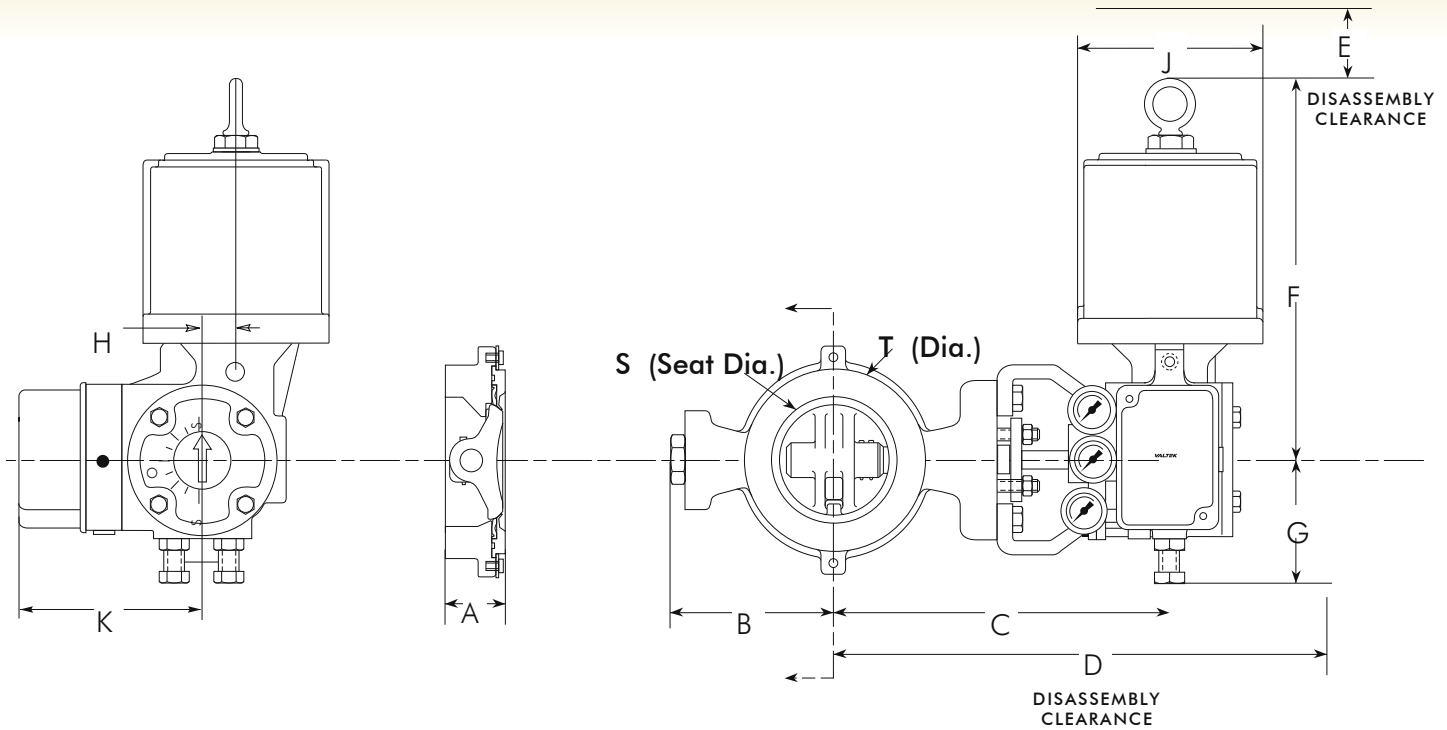

Table VII: DiskFlo Dimensions (inches/mm)

BODY CLASSES 150, 300, 600 $\text{D} 2$ thru 8-inch; 150, 300 $\text{D} 10$ thru 12-inch (with Class 150 or 300 disc and shaft)																										
Size (in.)	Actuator Size (sq.in.)	Shaft Size	Face-to- Face* A		B		C		D		E		F		G		H		J		K		S		T	
2	25	0.625	1.8	44	4.3	110	11.4	288	18.3	465	6.0	152	13.1	333	5.6	142	1.1	29	6.5	165	6.5	166	1.7	43	4.0	102
2	50	0.625	1.8	44	4.3	110	11.4	288	19.1	485	8.0	203	18.0	457	6.7	170	2.0	50	9.1	232	7.4	188	1.7	43	4.0	102
3	25	0.625	1.9	48	5.1	130	11.7	298	18.7	475	6.0	152	13.1	333	5.6	142	1.1	29	6.5	165	6.5	166	2.6	66	5.4	137
3	50	0.625	1.9	48	5.1	130	11.7	298	19.5	495	8.0	203	18.0	457	6.7	170	2.0	50	9.1	232	7.4	188	2.6	66	5.4	137
4	25	0.750	2.1	54	5.9	151	12.4	315	19.4	493	6.0	152	13.1	333	5.6	142	1.1	29	6.5	165	6.5	166	3.7	93	6.8	171
4	50	0.750	2.1	54	5.9	151	12.4	315	20.2	513	8.0	203	18.0	457	6.7	170	2.0	50	9.1	232	7.4	188	3.7	93	6.8	171
6	50	0.875	2.3	57	7.6	192	14.3	363	22.1	561	8.0	203	18.0	457	6.7	170	2.0	50	9.1	232	7.4	188	5.5	141	8.5	216
6	100	0.875	2.3	57	7.6	192	14.3	363	24.5	622	11.0	279	22.6	574	9.1	230	2.4	61	12.5	318	8.5	215	5.5	141	8.5	216
8	50	1.125	2.5	64	8.6	219	16.3	415	24.1	612	8.0	203	18.0	457	6.7	170	2.0	50	9.1	232	7.4	188	7.2	182	10.8	273
8	100	1.125	2.5	64	8.6	219	16.3	415	26.5	673	11.0	279	22.6	574	9.1	230	2.4	61	12.5	318	8.5	215	7.2	182	10.8	273
10	50	1.125	2.8	71	9.7	246	17.5	444	25.2	640	8.0	203	18.0	457	6.7	170	2.0	50	9.1	232	7.4	188	9.2	233	12.8	324
10	100	1.125	2.8	71	9.7	246	17.5	444	27.7	704	11.0	279	22.6	574	9.1	230	2.4	61	12.5	318	8.5	215	9.2	233	12.8	324
12	100	1.500	3.2	81	11.2	283	18.7	474	28.9	734	11.0	279	22.6	574	9.1	230	2.4	61	12.5	318	8.5	215	11.0	280	15.0	381

All dimensions are to be used for estimation only. Certified drawings will be supplied upon request.

For 14 thru 30-inch DC Valve contact factory.

* MSS SP67 Body Only

Table VIII: DiskFlo- Handwheel and Heavy-duty Spring Dimensions (inches/mm)

Actuator Nominal	E		F		M		N		P		R	
25	6.0	152	16.5	420	10.0	254	9.8	248	2.6	67	6.9	176
50	8.0	203	23.5	598	12.0	305	10.3	260	3.4	86	9.1	230
100	9.0	229	N/A		18.0	457	12.8	324	5.4	137	10.4	263
200	9.0	229	N/A		18.0	457	12.8	324	5.4	137	10.4	263

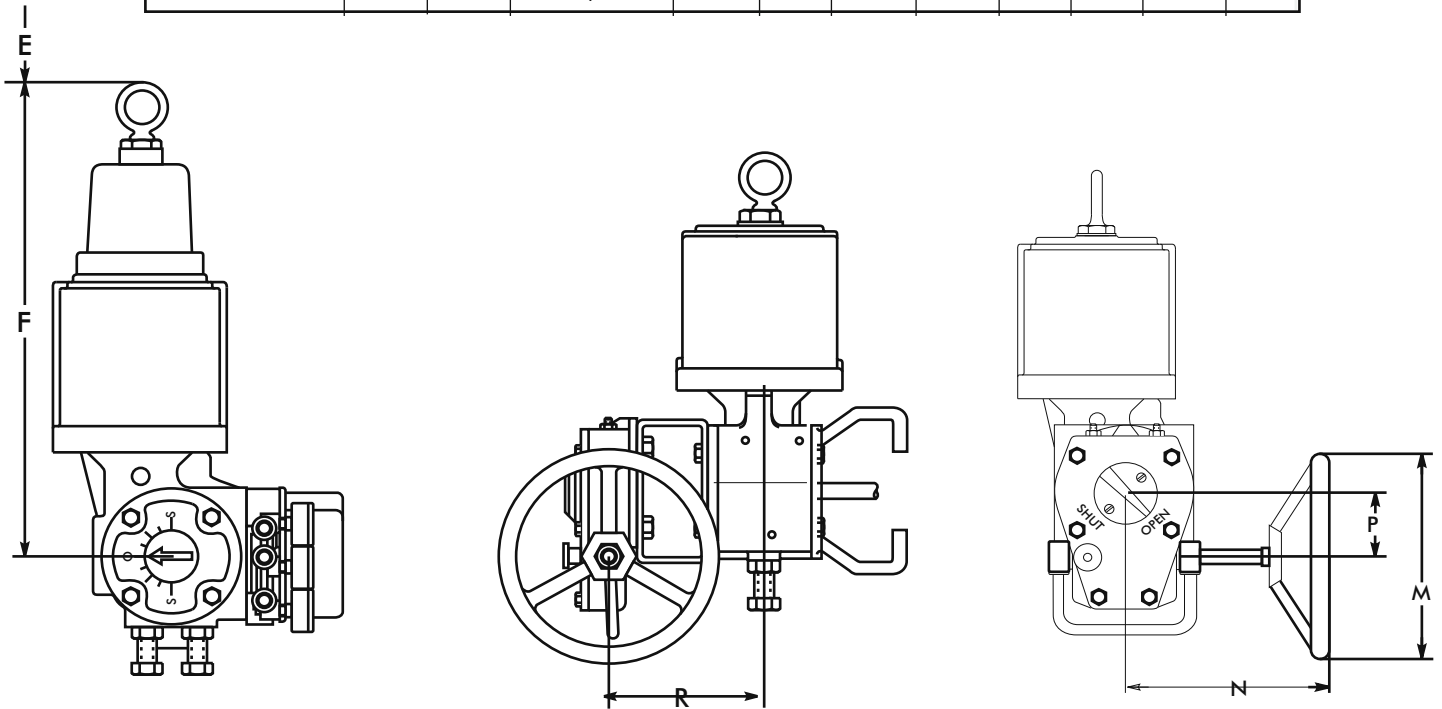

Ordering

While ordering a DiskFlo control valve, kindly provide the following information:

1. Preferred body size and critical dimensions
2. Start-up and operating conditions: inlet and outlet pressures; temperature, flow rate, fluids specific gravity or molecular weight, vapor pressure or gas compressibility
3. Maximum operating temperatures and pressures
4. Body and disc pressure rating
5. Materials required: body, disc, shaft, packing and bearings

6. Line size and schedule

7. Actuator requirements: type (pneumatic or manual), failure position, size and minimum air supply

8. Actuator position: style and orientation (Figure9)

9. Accessories required

DiskFlo Sizing

Procedures and data to size DiskFlo valves including determining actuator size are contained in MASCOT's Sizing & Selection manual.

DiskFlo

Various orientations

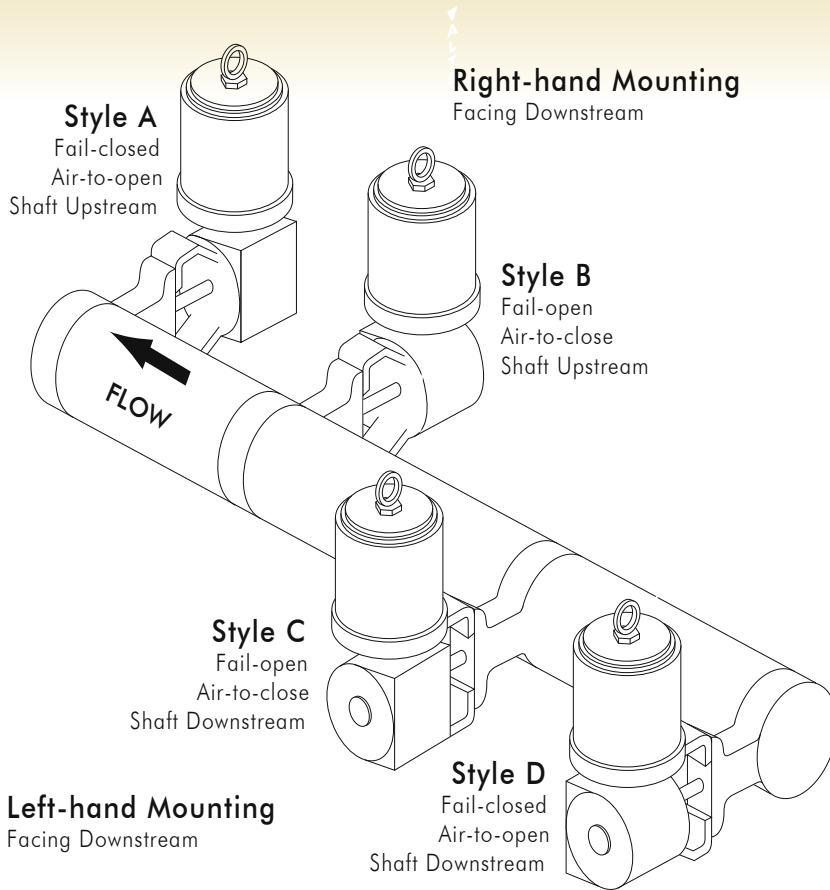

NOTE: Styles B and D may require a heavy-duty spring to achieve failure.

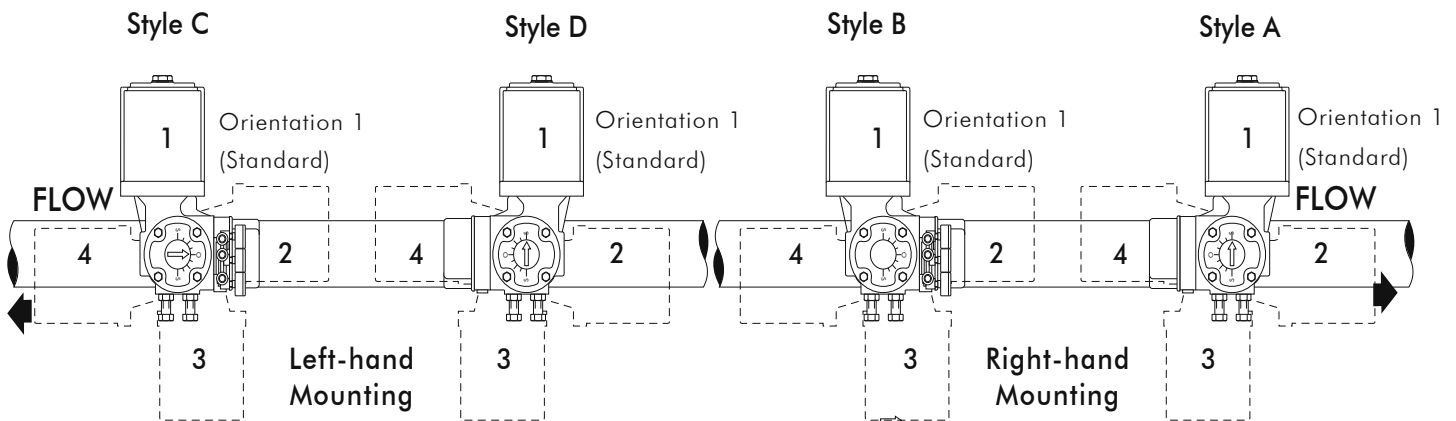

NOTE: Orientation 1 is standard. Orientation positions 2 and 4 are not available in some actuator sizes. Contact factory.

Figure10: Transfer Case Mounting