

Installation, Operation, Maintenance Instructions

GFlo and GFlo-II Control Valves

CAUTION :

1. Use pressure relief valves for high pressure piping.
2. Use explosion proof valves/accessories for dangerous media piping.
3. Use fire safe valves for piping where chances of fire by external means.
4. Use seismic proof valves where chances of earthquake are frequent.
5. Check whether location of the valve mounting is of the same service/application as specified on the marking plate.

 **MASCOT**

Our reputation

GENERAL INFORMATION

The instructions will assist in un-packing, installing and performing maintenance as needed on Mascot GFlo and GFlo-II control valves. Users of the product and maintenance personnel need to review this manual in detail before proceeding to install, operate or perform any procedures on the valve. Instructions for installation, operation, maintenance cover additional features (such as diaphragm actuator, special trim, extension bonnets, handwheel, etc.).

Information on Mascot positioners is not provided in this manual. For the installing, maintaining, troubleshooting, calibrating and operating Mascot positioners, refer to the separate manual.

Please follow the instructions as presented. This will help prevent any possible mishaps and injuries. Do not modify this product or substitute nonfactory parts. Do not use maintenance procedures other than the prescribed ones, otherwise the performance will be adversely affected and also will be hazardous to personnel and equipment. This will also cause the existing warranties to be null and void.

WARNING: When working on this, or any other, process control product. Adhere to standard industry safety practices. Personal, protective and lifting devices must be used as warranted.

Note: The onus of choosing the right fastener material lies on the customer. It is not possible for the supplier to know what the valve service conditions or environment exist. The standard body bolting material of Mascot's is B7/2H. There is an option of using B8 (stainless steel) for applications above 800° F / 425° C and with alloy body valves or stainless steel valves. The material's resistance to stress corrosion cracking in addition to general corrosion needs to be considered. *Periodic inspection and maintenance is required* as with any equipment. Your local Mascot representative or factory will happily provide information about fastener materials.

Spare Parts

Only high quality, factory-built parts are recommended to be used for servicing Mascot valves. In India Call 91+79+22821619 / 22823369 for information on spare parts.

Unpacking

1. During the unpacking of the valve, please check the packing list and verify against the received materials. Each shipping container is provided with the lists describing the valve and accessories that are supplied.
2. To avoid any possible damage to the tubing and mounted accessories during lifting the valve from the shipping container, position the lifting straps appropriately. Where the lifting ring is provided with Valves, (GFlo valves up to 6-inch, class 600) valves may be lifted using the actuator lifting ring. In case of larger valves, valve should be lifted using straps through the yoke legs or in case provided, lifting brackets bolted to bonnet studs.

WARNING : Pay attention to the center of gravity which may be above the lifting point when lifting an actuator with lifting straps through the yoke legs. In this case support is needed for preventing the rotating of actuator. Serious injury to personnel or damage to the valve and nearby equipment is likely if these instructions are not followed.

3. Please contact your shipper immediately in case you find any damage during transit.
4. In case of any help, please call us.

Installation

1. The first thing that needs to be done for installation of the valve is to make the surface free from dirt, welding chips, scale or any foreign material.
2. Preferably, the valve installation should be in a vertical position. Vertical installation makes maintenance of valve relatively easy. This position is important for cryogenic applications also, to keep the packing and flowing medium isolated. This thus allows the packing temperature and ambient temperature to remain quite close.

CAUTION: Extension bonnets provided for hot or cold services should not be insulated.

Table I: Overhead Clearance Requirement

Valve Size (Inches)/MM	Clearance (Inches)/MM	Valve Size (Inches)/MM	Clearance (Inches)/MM
0.5", 0.75", 1"	3/76	6"	10/254
1 1/2"	5/127	8"	13/330
3"	6/125	10"	14/356
4"	8/203	12"	15/381

3. To allow for disassembly of the plug from the valve body, ensure that proper overhead clearance for the actuator is provided. Table I presents the details for the necessary clearance needed for valve disassembly.
4. To ensure that the valve is installed correctly, double check flow direction. The arrow shows the flow direction. Typical air-to-open valves close on air failure and need to be installed as the flow tends to close the valve, except in rare circumstances that will be clearly indicated. Normal air-to-close valves open on air failure and need to be installed with the flow tending to open the valve.
5. Extreme care is advised while welding the valve to the line to avoid excess heat build-up in the valve.
6. Where the valve has separable end flanges - Before bolting the valve into the line, the half rings must be installed on the valve body to insure a tight connection.
7. Air supply and instrument signal (air or current) lines should be connected. If a valve positioner is present in throttling control valves, there are two connections marked; One for the air supply and second for the instrument signal. The actuator and positioner both are suitable for 150 psi / 10.3 Bar air supply.

WARNING : Serious personal injuries can be caused if failed to install half rings on the valve body.

Unless the supply pressure exceeds 150 psi / 10.3 Bar an air regulator is not needed. If the air supply is unusually clean and dry, preceding the positioner, an air filter needs not be installed. Ensure all connections are leak free.

CAUTION: For optimum performance of valves equipped with air filters, the air filter must point down else, the valve performance will be hampered.

NOTE : Rarely, the air supply needs to be limited to less than 150 psi / 10.3 Bar - In such cases, information is provided on a sticker pasted near the upper air port on the actuator cylinder. Installation of an air regulator ensures that the supply pressure does not exceed the line pressure indicated on the sticker.

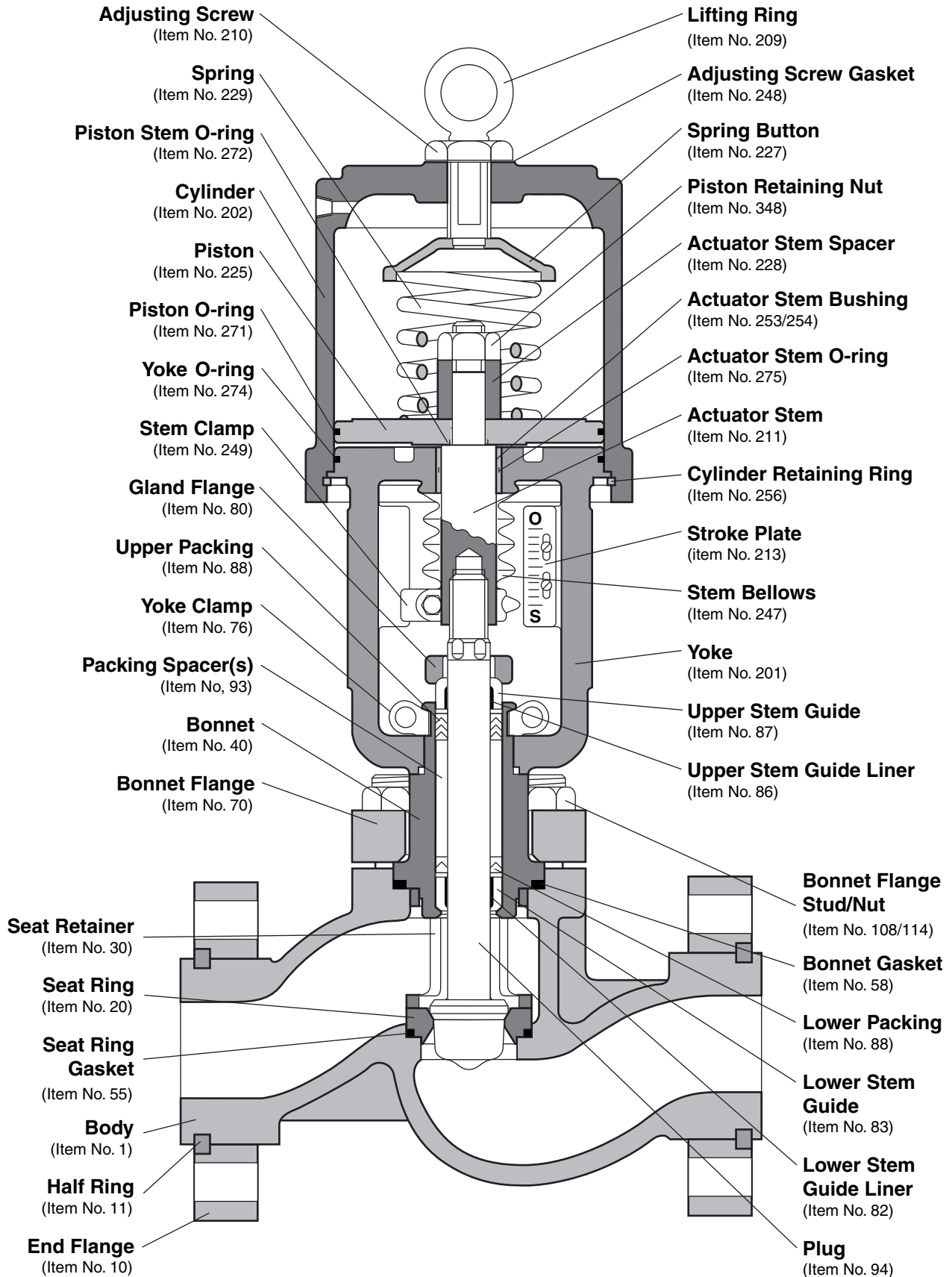

Figure 1: GFlo Control Valve

NOTE: Item numbers correspond to the bill of material of valve's. Please refer to it for specific part numbers.

Table II: Common Control Valve Lubricants

Lubricant	Manufacturer	Temperature Range (°F / °C)	Description Applications
Krytox 206	E.I. DuPont	-5° to 550 °F -20° to 285 °C	Fluorinated general purpose grease; handles common liquids and gases; good lubricity in harsh mediums; non-flammable, chemically inert; will not harm plastic or metal parts
GP 460	Graphite Products Co.	32° to 1000 °F 0° to 540 °C	Graphite in petrolatum; high pressures; anti-galling, graphite remains above 600 °F/316 °C
Aeroshell Grease 7	Shell Oil Co.	-100° to 300 °F -75° to 150 °C	Synthetic oil based; low temperature applications
Garlock Luball	Garlock Inc.	32° to 500 °F 0° to 260 °C	General purpose molybdenum disulfide lubricant economical; good in water, steam and common chemicals; not good in harsh mediums where Krytox 206 is recommended

Quick-check

Before start up, the control valve should be checked by following steps:

- Apply Stroke to the valve and see the plug position indicator on the stem clamp vis-à-vis the stroke indicator plate. The change of plug position should be in a smooth and linear fashion.
- By making appropriate instrument signal change (such as 3-15, 3-9, 9-15 psi / 0-1.0, 0 to 0.6, 0.6-1.0 Bar or associated split ranges for pneumatic positioners, 4-20 or 10-50 mA for electro pneumatic positioners), Check for full stroke.
- Leaks should be checked for all air connections.
- The packing nuts need to be adjusted to slightly over finger-tight force.
CAUTION : Over-tightening of packing causes excessive packing wear and high stem friction that may impede plug movement.
- In case of air failure, ensure that the valve fails in the correct direction. Accomplishing of this is done by observing the failure direction after turning off the air supply.
- Following temperature excursion, the retightening of bonnet flange bolting should be carried out to ensure bonnet gaskets do not leak. Refer Table III.

VALVE MAINTENANCE

Check the valve for proper operation, least once every six months by following the preventative maintenance steps presented below. The steps can be performed with the valve in-line and without interrupting service. In case of an internal problem, "Valve Disassembly and Reassembly" section needs to be referred.

- Gasket leakage is to be observed through the bonnet and end flanges. Tighten flange and bonnet bolting (if required). Refer Table III.
- Fluid leakage to the atmosphere needs to be checked for through the pressure-balance sleeve, metal bellows seal,

- Careful examination of the valve needs to be done to check for damage caused by process drippings or corrosive fumes.
- In areas of severe oxidation, clean valve and repaint
- Packing box bolting must be checked for proper tightness. Tightness of packing nuts should be slightly over finger-tight; however, to prevent stem leakage, tighten only as necessary.
CAUTION : Over-tightening of packing. Leads to leakage.
- If the valve is supplied with a lubricator fitting, check lubricant supply and add lubricant if necessary. See Table II for common lubricants.
- Where possible, stroke the valve and check the full-stroke and smooth operation. Unsteady stem movement could be an indication of problem inside the valve.
NOTE : Whenever graphite packing is used, jerky stem motion is normal.
WARNING : When operating the valve, body parts, clothing, etc. should be away from all moving parts as this may lead to serious injuries.
- Ensure the secure fastening of positioner linkage and stem clamp. Check plug thread engagement (refer to the "Reassembling the Actuator" section for the correct procedure on aligning the plug with the seat) if the stem clamp is loose.
- Ensure secure fastening of all accessories, brackets and bolting.
- Remove air supply and observe actuator for correct fail-safe action - if possible.
- Rubber bellows wear should be checked.
- For checking of air leaks through the O-rings, spray a soap solution around the cylinder actuator retaining ring, adjusting screw and actuator stem guide.
- The plug stem should be clean and free from any dirt and other foreign material.
- In case an air filter is supplied, checking and replacing cartridge should be undertaken if needed.

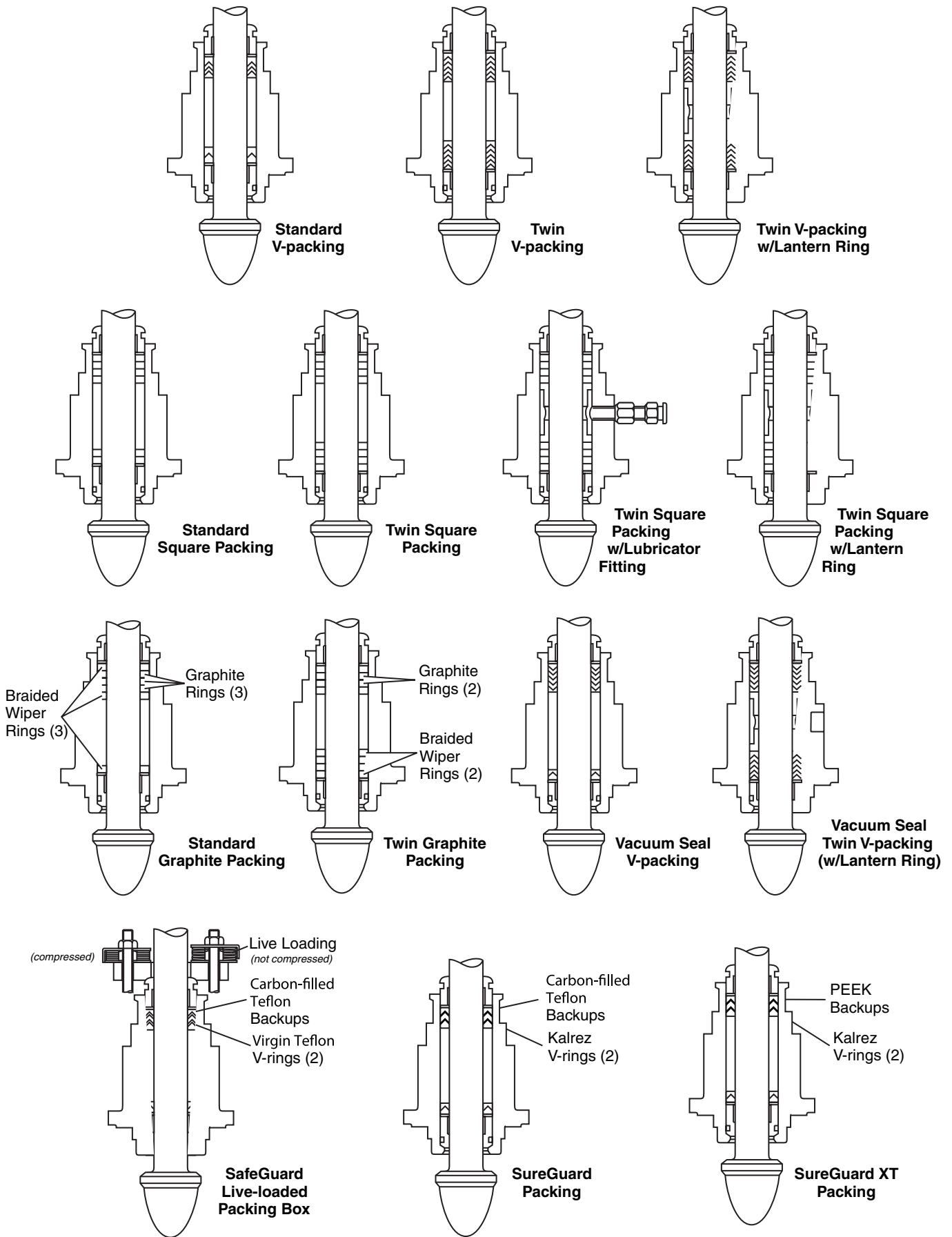

Figure 2 : Typical Packing Configuration

Note : See step 1 in " Reassembling the Body" section.

VALVE DISASSEMBLY AND REASSEMBLY

Body Disassembling

Refer to Figures 1 and 4 and proceed as given below :

WARNING : Pipe Line on which the valve is mounted needs to be depressurized to atmospheric pressure and all fluids should be drained before resuming work on the valve. In case of non-compliance there can be serious injury.

1. In case the valve is air-to-open, to lift pressure-balance sleeve, metal bellows seal, body drain plug, etc., apply air under the piston if included. If the valve is air-to-close, proceed to step 2.

2. The bonnet flange bolting needs to be removed to lift actuator, bonnet and plug out of the valve.

CAUTION : A hoist might be needed for heavy actuators. Most actuators have a lifting ring for this purpose; else, the valve can be lifted with the yoke legs using a lifting strap and a hoist. Lifting the actuator needs great care and to avoid damage to the plug and seat plug straight out of the body.

3. Lift retainer, seat ring and gaskets of the body.

4. Check to see that the seating surfaces on both the seat ring and plug are free of damage to ensure tight Shutoff

5. For inspection of the plug, remove it by loosening the stem clamp and gland flange and by taking off the yoke clamps.

NOTE : It may be necessary to apply a small amount of air to the top of the actuator to move the plug away from the bonnet in case of air-to-close, fail-open valves, otherwise some galling on the plug may occur.

Turn the actuator off the plug and bonnet without allowing the plug to rotate within the bonnet. The plug needs to be pulled carefully through the packing box.

CAUTION : To avoid scoring guides and plug stem, strictly follow the above.

6. Both surfaces on plug and seat ring must be reworked if the seat surfaces need remachining. The seat angle on the plug is 30 degrees (36 degrees for CavFlo and Channel Flo valves); the seat ring, 33 degrees. If proper assembly procedures are followed, Lapping will not be necessary.

CAUTION : Protect the stem during turning if remachining. Concentricity of the seat surface with the plug stem (or outside diameter of the seat ring, if machining the seat) must be ensured.

7. Push out packing, spacer and guides from underneath the bonnet with a dowel of the same approximate size as the plug stem to replace packing or change the packing box configuration.

WARNING : Do not machine body gasket surfaces for valves equipped with separable end flanges. Machining could cause failure of the separable flange lip causing end gasket leakage and failure of the valve.

8. For separable flanges, file off tack welds or pull rivets behind the flanges If separable end flanges need to be removed.

CAUTION : Use gaskets with outer backup rings, when using separable end flanges with spiral wound gaskets. Failure to do so could result in excessive stress in some applications.

NOTE : A tack weld or stainless steel rivet has been installed behind the end flanges to prevent flanges from dropping off during shipping.

Reassembling the Body

1. Refer to Figures 1, 2 and 4 and proceed as follows to reassemble the valve body: 1. Refer to Figure 2 and reinstall new packing exactly as shown, if the packing has been removed. Make sure at least 1/8" is left at the top of the packing box for the top guide to enter. Different spacer lengths permit a wide variety of packing configurations, such as twin seal and vacuum-pressure packing.

WARNING : Valves that have extended bonnets or metal bellows seals must not have lower packing installed. Instead, lower packing rings should be installed with the upper set. Lower packing installed in extended bonnets or metal bellows seal valves will diminish the integrity of the packing assembly.

Graphite liners should be replaced each time the valve packing is replaced, where graphite guides are used. Under no circumstances should the valve be rebuilt without graphite liners in the guides.

2. Being careful not to score the stem or the guides, reinsert the plug stem into the packing box.

3. Without turning the plug inside the bonnet, turn actuator back onto the plug, making sure the gland flange and bonnet flange are in place before engaging the plug stem and actuator stem threads.

NOTE : Do not allow the gland flange to contact and gall the polished plug stem.

Leave approximately three to four plug stem threads exposed. Attach yoke clamp and gland flange bolting. For valves with a 2" spud, be sure the half rings are in place between the yoke and bonnet. Tighten yoke clamp bolting firmly. The packing box nuts should be just over finger tight.

4. Install new bonnet and seat gaskets. Beveled edge up for teflon gaskets.

5. With the step side down, insert the seat ring into the body. With the thin end of the cathedral window down, place the seat retainer into the body.

NOTE : ANSI Class 900 and above rated valves and valve sizes up through 1 1/2 -inch, the seat retainer window should be placed in the body with the window facing toward the valve ports. For valves 2" and larger, the retainer's bore should face toward the valve ports.

6. On air-to-open valves to retract the plug, place air under the actuator piston.

7. Being careful not to scratch or gall the plug as it enters the body, lower the plug and bonnet squarely into the body.

8. First bring the bonnet bolting to finger tightness, to properly align the seat ring and plug.

A. Apply air pressure above the piston to seat the plug in the seat ring, with pneumatic actuators and proceed to step 9.

B. Move the actuator stem down until it is completely extended, for electric or hydraulic actuators. Now retract the actuator stem 1/8" / 3.175 mm. Install the stem clamp onto the plug stem/ actuator stem and tighten the associated bolting. Move the actuator stem down fully. Adjust actuator limit switches according to the actuator's operating manual.

NOTE : Step 9 applies only to valves with pneumatic actuators. If an electric or hydraulic actuator is used, return the plug to the mid-stroke position and proceed to tighten.

CAUTION : Failure to return the plug to a mid-stroke position (electric or hydraulic actuators only) will cause damage to the actuator and/or the valve during the bonnet tightening sequence. This is due to the inability of most electric / hydraulic actuators to accommodate the 1/16" / 1.60- mm back-drive during the tightening sequence.

9. For air-to-close valves, skip this step and go to step 10. For air-to-open valves, check for proper plug seating as follows: When proper seating occurs, the bonnet flange will be forced up against the finger tight body bolting with such force that it will be impossible to wiggle the flange. If proper seating does not occur, the bonnet flange can be wiggled with light hand force. Should this occur, place air under the actuator piston and retract the actuator to approximate mid-stroke position. Turn the plug out of the actuator plug stem one additional thread and repeat above seating procedure. When the bonnet flange becomes tight against the finger tight body bolting, the plug is properly seated. If necessary, repeat above procedure until proper seating occurs.
10. Move the plug to the extended (or closed) position for pneumatic actuators and to the mid-stroke position for electric, hydraulic or mechanical actuators. Begin tightening the bonnet flange bolting in a manner that will keep the bonnet flange square/ parallel with the body. Tighten the first bolt 1/6 turn, and then tighten the bolt directly opposite 1/6 turn and so on around the flange. Firmly tighten all bolts evenly and completely to compress the bonnet gasket and to seat the bonnet. Torque the bonnet bolts to the suggested torque values in Table III.
11. Apply air over the piston to seat the plug. For all throttling valves, adjust the stem clamp so that with full instrument signal to the positioner the full signal scribe line on the positioner cam points to the center of the cam roller bearing.

NOTE : For on/off valves, the bottom of the stem clamp should simply be lined up with the bottom of the actuator stem (plus or minus 1/16" / 1.60 mm).

Tighten the stem clamp bolting. Proper tightness is important since this adjustment secures the actuator stem to the plug stem. Adjust the stroke plate so that the stem clamp points to the "closed" position.

12. If the valve has been taken out of the line, make sure the flow arrow indicates proper flow direction upon reinstallation.

Table III : Suggested Bonnet Bolting

Size (inches)	Carbon Steel	Stainless Steel
5/8	80/108	50/68
3/4	140/190	90/122
7/8	230/312	150/203
1	350/475	220/298
1 1/8	510/690	330/447
1 1/4	730/990	460/624
1 3/8	990/1342	630/854
1 1/2	1320/1790	840/1140
1 5/8	1710/2318	1080/1484
1 3/4	2170/2942	1400/1898
1 7/8	2700/3660	1700/2305
2	3350/4542	2100/2847

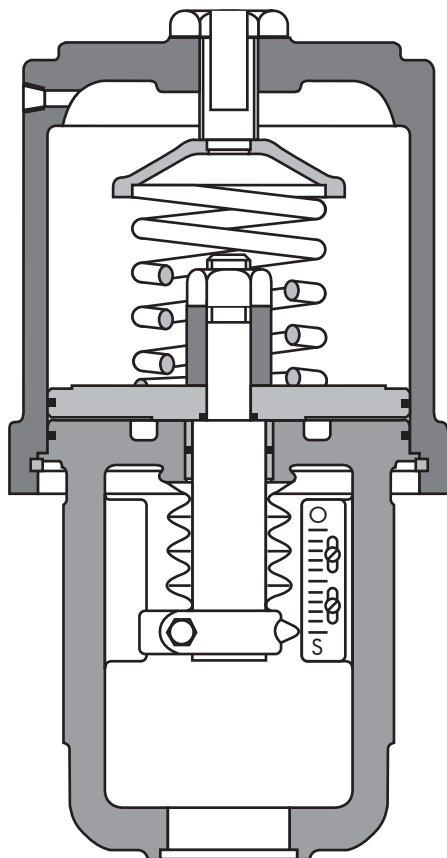

Air-to-open

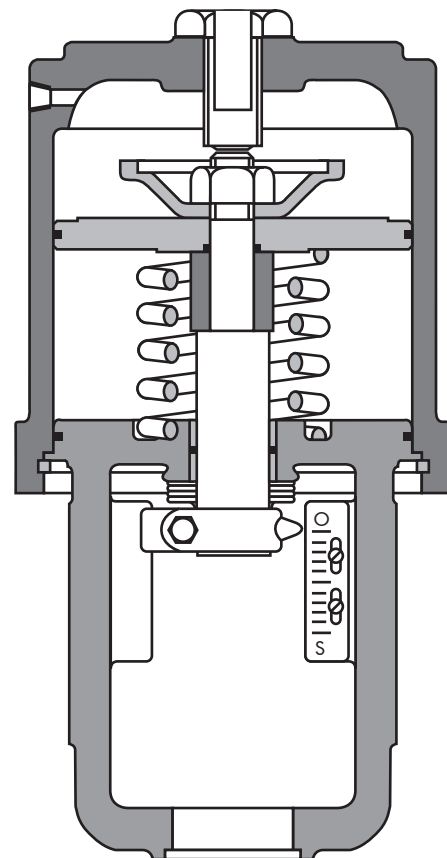

Air-to-close

Figure 3 : Air-action Configurations

Disassembling the Actuator

Air-to-open valves : Actuator may be disassembled while on the valve.

Air-to-close valves : Actuator must be removed from the valve prior to disassembly.

Refer to Figures 1, 3 and 5 for disassembling the actuator, and proceed as follows:

NOTE : Steps 1-4 are to be followed for removing the actuator from the valve. Go on to step 5 if disassembly is to take place with the actuator still attached to the valve.

1. Plug should neither be seated on the seat ring nor back seated against the bonnet. To do this, apply air on the appropriate side of the cylinder and release the pressure on opposite side

2. Loosen the stem clamp.

3. Remove packing box bolting and yoke clamps.

4. Completely turn the actuator off the plug and bonnet without rotating the plug inside the bonnet.

CAUTION : Do not allow the plug to drop and impact against the seat after turning the actuator off the plug threads.

5. Disconnect tubing.

6. Relieve the spring compression by loosening the adjusting screw.

CAUTION : Do not use a screwdriver through the lifting ring to remove the adjusting screw; as this may damage the weld between the lifting ring and adjusting screw.

WARNING : To avoid serious personal injury during disassembly, the spring compression must be relieved before further disassembly.

7. Remove the retaining ring from the groove at the base of the cylinder by using two screwdrivers, inserting them in the ring's slot and prying the ring from the groove.

8. Pull the cylinder off of yoke and piston. Some O-ring resistance may be felt. Remove spring for cleaning and inspection (air-to-open configuration only).

WARNING : Do not use air pressure to remove cylinder. Serious personal injury can occur.

9. Remove the piston retaining nut and slide piston off of the actuator stem, to remove the spring on air-to-close configurations. The spring may now be removed.

NOTE : Step 10 can only be performed only if the actuator has been removed from the valve.

10. Remove the stem clamp and bellows for inspecting the actuator stem O-ring. While being careful not to gall the stem, push the actuator stem through the yoke. The O-ring may now be removed for replacement.

NOTE : It is not necessary to remove the bushing to replace the actuator stem O-ring as the actuator stem bushings are pressed into the yoke.

Reassembling the Actuator

To reassemble the actuator, refer to Figures 1, 3 and 5 and proceed as follows:

1. All O-rings should be replaced and the new ones to be used duly lubricated. Most O-rings should be lubricated with a silicone lubricant (Dow Corning 55M or equivalent). (Silicone O-rings must be lubricated with Magnalube-G lubricant or equivalent. Do not use a silicone lubricant on silicone O-rings.)

2. Before beginning reassembly, make sure all internal parts are thoroughly cleaned and lubricated

3. Replace the piston stem O-ring and reassemble the piston and actuator spacer on the actuator stem according to the proper air-action (refer to Figures 3 and 5), If the actuator stem has been removed. Air-to-close configurations require the spring button to be inserted under the actuator stem retaining nut. Tighten the retaining nut firmly.

4. For air-to-close configurations, place the spring under the piston and insert the actuator stem through the yoke, being careful to not gall the stem or the bushings. Make sure the spring is retained in the groove provided in the top of yoke. For air-to-open configurations, insert the actuator stem through the yoke and place the spring and spring button above the piston.

5. Making sure the yoke is pushed deep enough into the cylinder to allow the retaining ring to be installed, install the cylinder.

6. Reinsert the retaining ring by feeding it into the groove a little at a time until it snaps in place. Replace the stem bellows and stem clamp.

7. Reinstall the gasket and adjusting screw, using a new adjusting screw gasket. Tighten the adjusting screw only enough to provide an air seal with the gasket. Do not over tighten.

NOTE : On air-to-open configurations, make sure the hole in the spring button is directly centered under the adjusting screw hole.

CAUTION : Do not use a screwdriver through the lifting ring to remove the adjusting screw; as this may damage the weld between the lifting ring and adjusting screw.

8. Apply air over the piston and place the actuator subassembly onto the valve, making sure the gland flange and bonnet flange are in place. For valves with a 2" spud, be sure the half rings are in place between the yoke and bonnet. Engage the plug stem and actuator stem threads. Carefully turn the actuator clockwise until the plug stem is engaged 3 to 4 turns.

CAUTION : To avoid possible stem and/or seat galling, do not allow the plug to turn on the seat.

9. Apply sufficient air under the piston (for air-to-open valves) or over the piston (for air-to-close valves) to prevent the plug head from touching either the seat or the bonnet. Continue turning the plug stem into the actuator stem until 2 to 3 plug stem threads remain exposed.

CAUTION : Do not allow the gland flange to contact or gall the polished plug stem.

CAUTION : To avoid possible stem and/or seat galling, do not allow the plug to turn on the seat.

10. Apply air over the piston. This will drive the plug into the seat and lift the yoke off the bonnet approximately 1/16" / 1.60 mm. If the space is not 1/16" / 1.60 mm, apply air under the piston to retract the actuator stem and screw the plug in or out as needed. Repeat this step until the 1/16" / 1.60 mm space is created.

11. Attach the yoke clamps and packing box bolting, by applying air under the piston. Tighten the yoke clamp bolting firmly. The packing box nuts should be just over finger-tight.

CAUTION : Over tightening of packing can cause excessive packing wear and high stem friction that may impede plug movement.

- Apply air over the piston to seat the plug. For all throttling valves, adjust the stem clamp so that with full instrument signal to the positioner the full signal scribe line on the positioner cam points to the center of the cam roller bearing.

NOTE : For on/off valves, the bottom of the stem clamp should simply be lined up with the bottom of the actuator stem (plus or minus 1/16" / 1.60 mm). Tighten the stem clamp bolting. Proper tightness is important since this adjustment secures the actuator stem to the plug stem. Adjust the stroke plate so that the stem clamp points to the "closed" position.

- Reconnect the actuator/positioner tubing, supply and signal lines.

REVERSING THE AIR-ACTION

Changing to Air-to-Open

To change the air-action from air-to-close to air-to-open, refer to Figures 3 and 5 and proceed as follows:

- Follow the instructions for disassembling the actuator (see "Disassembling the Actuator" section).

- Reassemble the actuator with the spring, actuator stem spacer and spring button over the piston. For proper alignment, the center hole in the spring button should engage the end of the adjusting screw.
- The position of the positioner must also be changed. To do this, refer to the appropriate positioner installation, operation, and maintenance instructions.

Changing to Air-to-Close

To change the air action from air-to-open to air-to-close, refer to Figures 3 and 5 and proceed as follows:

- Follow the instructions for disassembling the actuator (see "Disassembling the Actuator" section).
- Reassemble the actuator with spring and actuator stem spacer below the piston. The spring should sit in the spring groove on top of the yoke. The spring button is not used on air-to-extend configurations and is stored above the piston (the actuator stem retaining nut holds the spring button in place).
- The position of the positioner must also be changed. To do this, refer to the appropriate positioner installation, operation, and maintenance instructions.

Troubleshooting Chart

Problem	Probable Cause	Corrective Action
Stem motion impeded	<ol style="list-style-type: none"> Overtightened packing Service temperature is beyond operating limits of trim design Inadequate air supply 	<ol style="list-style-type: none"> Adjust packing box nuts to slightly over finger-tight Reconfirm service conditions and contact factory Check for leaks in air supply or instrument signal system; tighten loose connections and replace leaky lines Malfunctioning positioner 4. Refer to positioner maintenance instructions
Excessive leakage	<ol style="list-style-type: none"> Improperly tightened bonnet flange bolting Worn or damaged seat ring Worn or damaged seat or bonnet gasket Inadequate actuator thrust Incorrectly adjusted plug Improper flow direction Improper handwheel adjustment acting as a limitstop 	<ol style="list-style-type: none"> Refer to step 3 of "Reassembling the Body" section for correct tightening procedure Disassemble valve and replace or repair seat ring Disassemble and replace gaskets Check for adequate air supply to actuator; if air supply is adequate, reconfirm service conditions and contact factory Refer to steps 8 - 10 of "Reassembling the Body" section for correct plug adjustment Refer to original specifications or contact factory Adjust handwheel until plug seats properly
Inadequate flow	<ol style="list-style-type: none"> Improper plug adjustment, limiting stroke Malfunctioning positioner Service conditions exceed trim design capacity 	<ol style="list-style-type: none"> Refer to steps 8 - 10 of "Reassembling the Body" section for correct plug adjustment Refer to positioner maintenance instructions Verify service conditions and consult factory
Plug slams	<ol style="list-style-type: none"> Incorrect plug adjustment allowing improper cushion of air between actuator piston and yoke Inadequate air supply remove any restrictions in supply line Trim sized too large for flow rate 	<ol style="list-style-type: none"> Refer to steps 8 - 10 of "Reassembling the Body" section for correct plug adjustment Check air supply to actuator; repair leaks and Install reduced trim
Valve does not fail in correct position	<ol style="list-style-type: none"> Incorrect flow direction 	<ol style="list-style-type: none"> Reconfirm direction and, if necessary, correct flow direction through valve

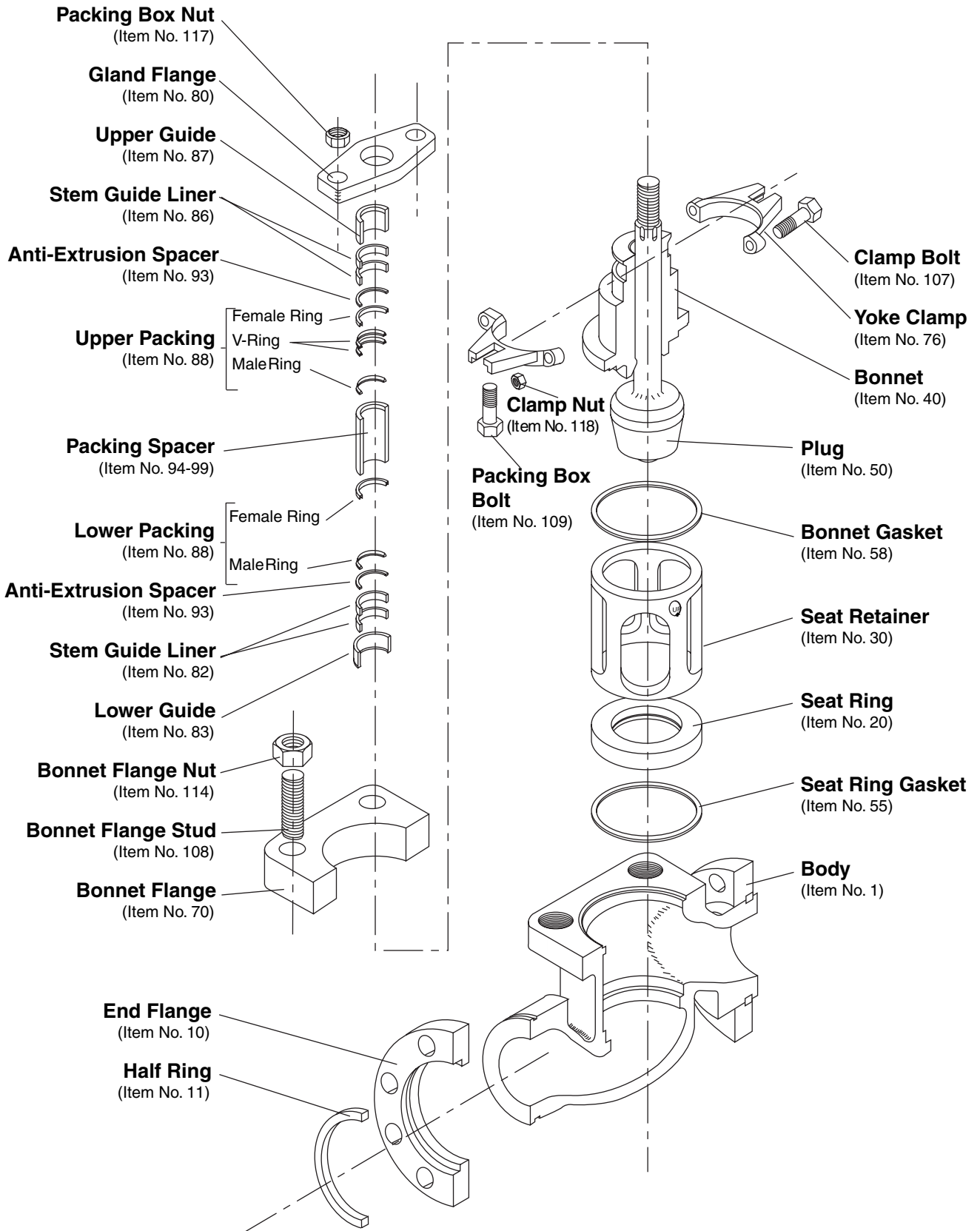

Figure 4 : Exploded View - Body Assembly

Note : Item numbers correspond to bill of material of Actuator. Please refer to it for specific part numbers.

AIR-TO-RETRACT

AIR-TO-EXTEND

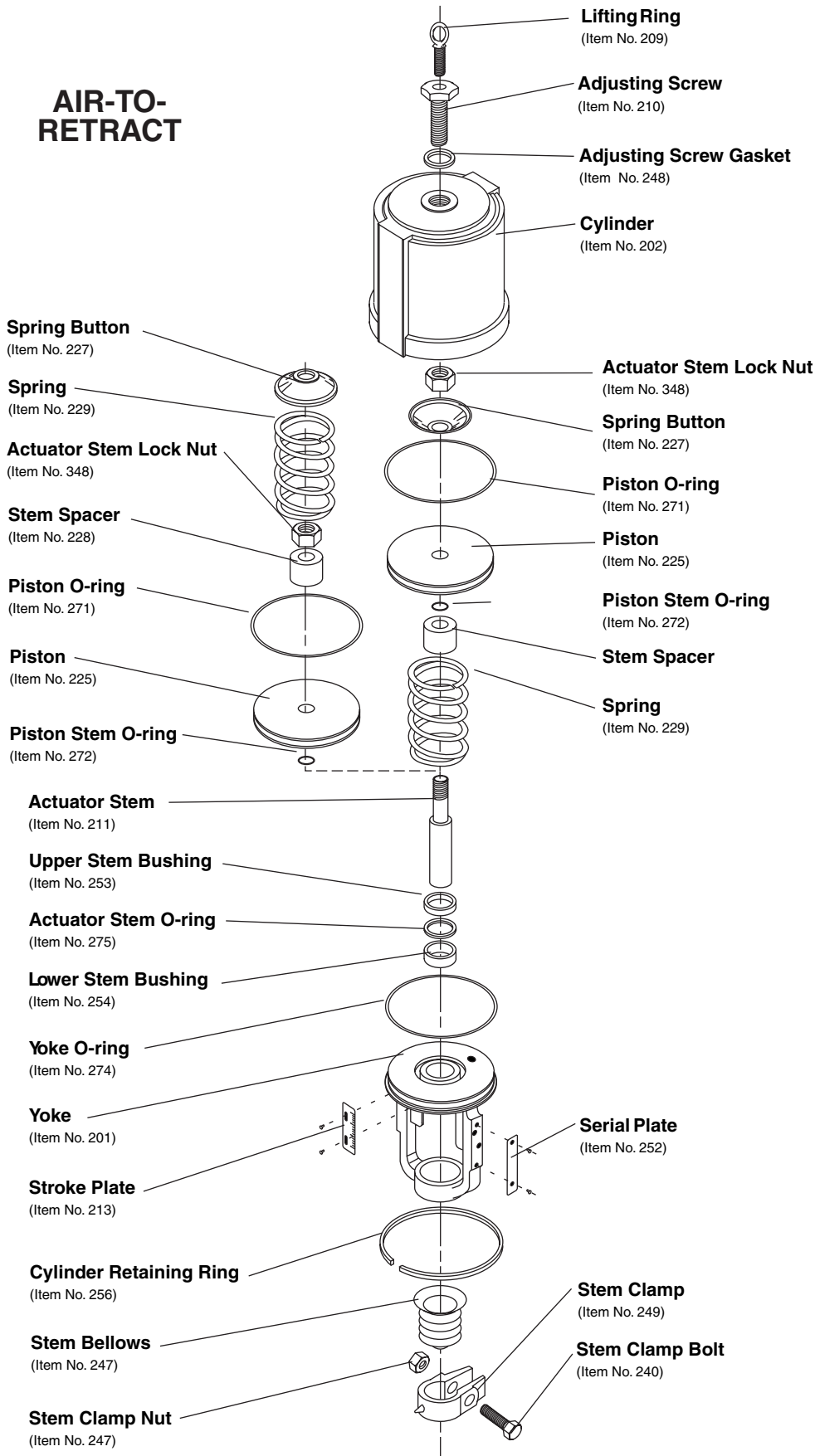

Figure 5 : Exploded View - Actuator Assembly

Note : Item numbers correspond to bill of material of Actuator. Please refer to it for specific part numbers.



Our reputation

MASCOT VALVES PVT. LTD.

166 / 167, G I D C, Naroda, Ahmedabad : 382330. India

Phone : +91 79 22821619/22823369, Fax : +91 79 22822430

Email : info@mascotvalves.com / web : www.mascotvalves.com